

# CENTRIFUGAL PUMP

**Centrifugal Pumps** are suitable for both domestic and industrial applications to convey clean liquids and non-aggressive chemical fluids. These pumps are characterized by low head and high capacity.

## 60Hz - Technical parameter

Model	Voltage	Frequency	Power		Current	H.Max	Q.Max	Size	S.Head	G.W
			kW	HP	amp	m	L/min	inch	m	kg
HFM/1B	110V/220V	60Hz	0.6	0.8	6.9/3.5	16	275	G1.5"×G1.5"	8	12.5
HFM/1A	110V/220V	60Hz	0.75	1	10/5.5	20	275	G1.5"×G1.5"	8	13.5
HFM/5C	110V/220V	60Hz	0.6	0.8	6.9/3.5	12.5	500	G2"×G2"	8	13.8
HFM/5B	110V/220V	60Hz	0.75	1	10/5.5	14	600	G2"×G2"	8	14.0
HFM/5A	110V/220V	60Hz	1.1	1.5	14/7.5	15	650	G2"×G2"	8	14.7
HFM/6C	110V/220V	60Hz	1.1	1.5	14/7.5	12	1100	G3"×G3"	8	26.6
HFM/6B	110V/220V	60Hz	1.5	2	17/8.5	15	1200	G3"×G3"	8	27.8
HFM/6A	220V	60Hz	2.2	3	12	19	1300	G3"×G3"	8	28.6
HFM/7B	220V	60Hz	3	4	14	22	1300	G3"×G3"	8	38.5

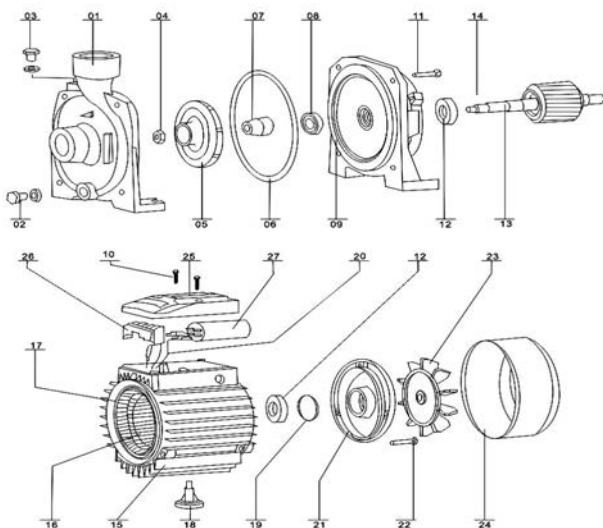
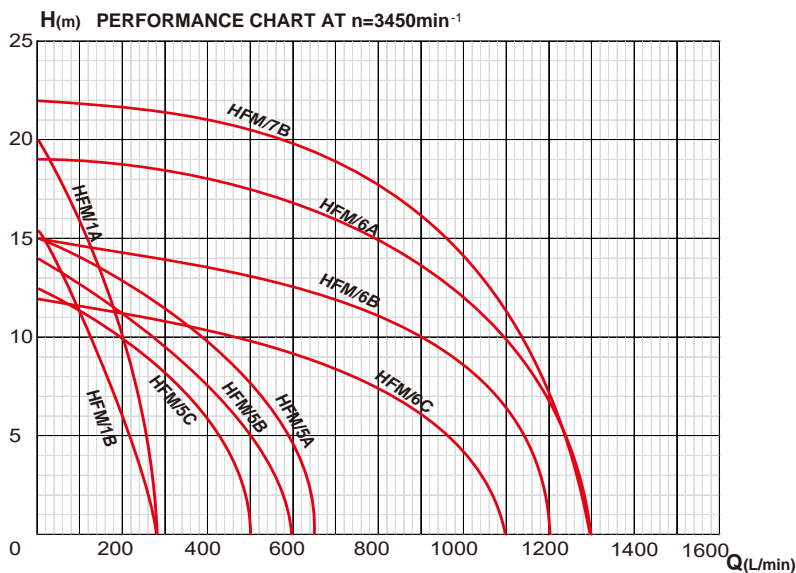

**EXPLODED VIEW DRAWING - SPARE PARTS**

No.	Description.	No.	Description
1	Pump Body	15	Motor Body
2	Screw	16	Stator
3	Flit Plug Screw	17	Stator Coil
4	Looking nut	18	Motor Foot
5	Impeller	19	Spring Washer
6	O Ring	20	Connection Wire
7	Mechanical Seal	21	Motor End cover
8	Mechanical Seal	22	Tie Bolt
9	Motor Front cover	23	Fan
10	Screw	24	Fan Cover
11	Screw	25	Terminal Cover
12	Ball Bearing	26	Terminal Block
13	Motor Rotor	27	Capacitor
14	Shaft key		

available also in 50Hz